



Introduction to the BKV Go Condition Monitoring Solution

BKV Go is an “off the shelf” solution offering basic Condition Monitoring to customers having limited experience and knowledge about Condition Monitoring. The solution offers easy to understand overviews of the vibration level of the monitored assets and it offers recommendations for how to investigate the error cause in case of alarm activity. The vibration level insights of BKV Go will enable production plants to start doing machine health management based on actual vibration insights.

The BKV Go Solution is ideal for monitoring the condition of industrial motors, pumps and fans (or a combination of these), which might require the implementation of a Condition Monitoring system. For the solution to work properly it is a requirement that the monitored motors, pumps and fans rotate at steady state speeds (nominal operation).

The solution consists of a condition monitoring edge device (the VCM-3) installed in a steel housing, sensors, and cables. The device is cable-connected to a set of sensors mounted on the assets to be monitored.

The solution can either be used as a stand-alone solution or be connected to your own network – the choice is yours.

The BKV Go Solution consists of the following elements:

- A dedicated device commissioning website offering an easy-to-use, guided process for creation of the device configuration.
- A local website-based dashboard on the device offering clear insights into the status of the vibration level of the monitored assets. The connection to the dashboard from your PC (local or remote) is done via the corresponding IP address.
- A recommendations matrix offering guidance on how to investigate error causes is built into the dashboard solution. The recommendations will hint maintenance crews in the direction of possible causes.

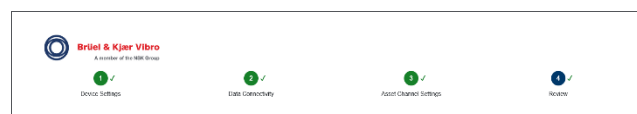
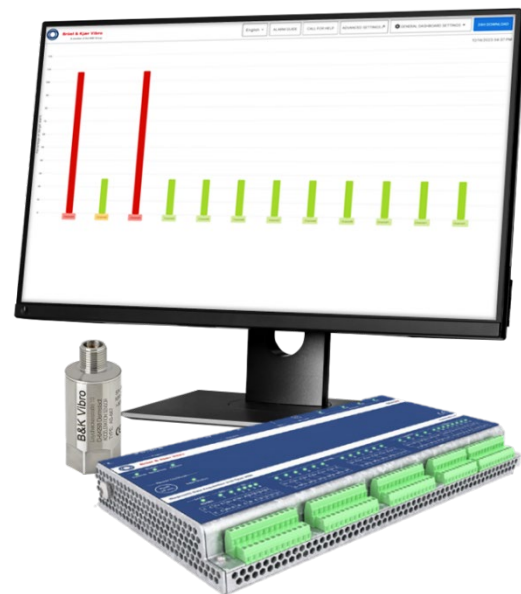

No software is needed to operate BKV Go – the dashboard is running on the device itself.

Internet access is only needed for the initial commissioning. Post commissioning the VCM-3 device can either be cable-connected to a portable PC as a stand-alone solution or be cable-connected directly to your company network.



BKV Go is available in 3 different package sizes:

- **2/1 Combo**
utilizing 4 device channels for the monitoring of up to 2 assets
- **4/2 Combo**
utilizing 8 device channels for the monitoring of up to 4 assets
- **6/3 Combo**
utilizing 12 device channels for the monitoring of up to 6 assets

Each of these packages can be ordered with or without an optional pre-defined cable package depending on your specific requirements. This gives you the option of ordering the cable lengths matching your specific needs.

The BKV Go package contains the following hardware:

- 1x VCM-3 condition monitoring device pre-installed in an IP66 certified steel housing which enables installations in rough environments
- 1x circuit breaker
- 1x power supply
- 1x acceleration sensor package (fitting the number of combo channels; type AS-667 acceleration sensor)
- 1x USB stick for the configuration process (also contains various documentation)
- 1x Quickstart Guide (printed)

Optional:

- 1x cable package (depending on package order code -WC; with cables)

Included in BKV Go is a 12-month free remote service support. This service covers support in commissioning BKV Go and in getting started.

In addition to that you have the option of entering a support contract which covers support in interpreting the BKV Go Dashboard results and in carrying out the error cause investigation. For more info, please contact your local B&K Vibro representative.

The BKV Go Solution is based on the VCM-3 Condition Monitoring hardware device which represents a high level of monitoring capabilities. Due to the high capability of the device, the solution can (if the needs grow over time) be upgraded to either BKV's cloud solution Beyond or the AVEVA PI based SETPOINT® CMS solution without any changes needed to the hardware.

The BKV Go Dashboard and the automatic alarm threshold setting

The BKV Go Dashboard delivers insights into the vibration level of the monitored assets and is delivered with an automatic alarm calculation function. The asset status is illustrated on two separate screens/dashboards.



The first screen/dashboard gives an overview of the status of the vibration level of the monitored assets in a bar diagram with the following denotation:

- Green** bar: ISO Condition overall vibration level is normal (no alarm).
- Yellow** bar: ISO Condition Overall vibration level is above the defined alert limit value and requires investigation.
- Red** bar: ISO Condition Overall vibration level is above the defined danger limit value and requires immediate investigation.

The above bars are based on the ISO Condition measurement of 10 Hz – 1 kHz defined in ISO standard 20816. The bars in the illustration represent the ISO condition measurement.

The “channel bubbles” at the bottom of the bars represent all four measurements captured by the BKV Go Solution (the color indicating the most severe condition measured).



The second screen shows the development (last hour) of the vibration level of a specific channel respectively the four subsequent condition measurements when more details are required.

It is also possible to download a 24h history (.csv format, can be processed e.g. with MS EXCEL) for all channels and all measurements individually or in one download.



BKV Go offers both manual and automatic setting of the alarm limit values.

The auto-calculation of the alarm limits starts automatically when BKV Go is commissioned and will be ready after approx. 1 hour of operation. BKV Go will detect machines/assets operating in idle. In this case the vibration values are not considered for the automatic alarm limit value calculation! If needed the auto-calculation can be executed again for an individual channel or for all channels by pushing a button on the Dashboard.

Alternatively, the alarm limit values of each channel or measurement can be set manually by the user and by this overwrite the auto-calculated values if desired.

The chosen alarm limit values subsequently guide the colors of the bars and “channel bubbles” on the screens.

In case an alarm is activated, the dashboard offers recommendations for what to investigate in order to identify error causes. The recommendations can be accessed directly from the dashboard by the push of a button. The insights from the dashboard can be incorporated into the maintenance management of the production plant.

For easy reference the user is free to name the channels in use.

The BKV Config website is used for configuring the device monitoring template prior to commissioning

By following the guided process on the website, the configuration template file for the device can be easily and swiftly created, downloaded on a USB stick or SD card and subsequently uploaded to the VCM-3 device.

Before starting the commissioning process the sensors should be installed and connected on the assets to be monitored according to the installation instructions supplied with the sensors.

The process as described in the Quickstart Guide:

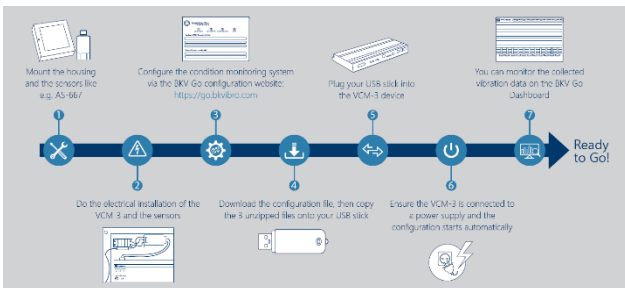

Go to link: <https://go.bkvvibro.com>

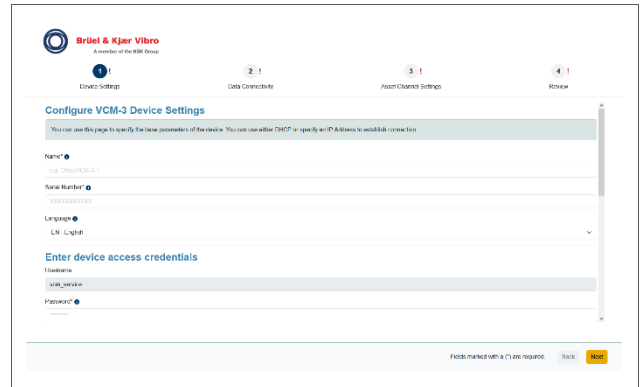

Follow the website guided process and the configuration for the device will be created.

Download the configuration (file) to your PC (local directory) and then onto the USB stick or SD card. Insert the USB stick or SD card, turn on the power of the device and the device will reboot automatically and upload the new configuration file from the USB stick or SD card. (USB stick or SD card can also be inserted while the device is already powered).

The configuration of the device is complete, and the BKV Go Condition Monitoring solution is initiated.

You can also download your configuration/device settings to a PDF for documentation purposes.



The VCM-3 device

A key component in the BKV Go Solution package is the VCM-3 condition monitoring edge device.

The VCM-3 in its standard configuration is a powerful 24-channel edge device, ideal for permanent (on-line) monitoring of auxiliary machines. The combination of comprehensive, highly flexible vibration measurements together with processed data allows monitoring of your assets and operation in the edge, i.e. edge computing on asset floor level.

This has the benefit of providing:

- Early bearing fault detection
- Application specific solutions to monitor operations and process
- Eliminating walkaround (off-line) programs that may find problems too late
- Removing personnel from dangerous areas

VCM-3 provides twelve dynamic channels that can each return measurements for:

- Bandpass (with option for integration)
- Narrowband (with option for integration or double integration) amplitude and phase
- Acceleration enveloping (ECU)
- Narrowband acceleration enveloping (with option for integration)
- Asynchronous, synchronous, and enveloping waveforms
- Bias voltage/gap measurement
- Bearing Condition Unit (BCU)

In addition, the following channels are also provided:

- Four tachometer channels to provide speed and phase reference
- Eight process variable channels (4–20 mA inputs)

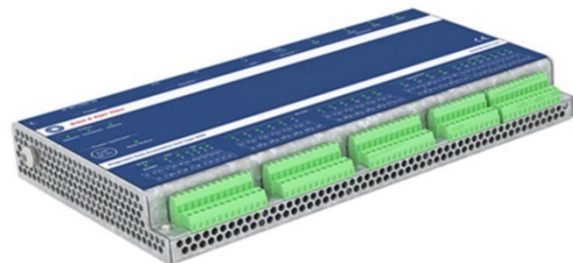

The VCM-3 provides an easy-to-implement vibration condition monitoring solution to detect potential failure modes of your production assets that could, if not checked, result in a catastrophic failure, downtime, and production loss. The fault detection measurements offer an "Early Warning System" that brings go/no-go decisions directly into the control room as part of regular plant operations. In addition to actionable information, the VCM-3 instantly feeds filtered and refined vibration health data to the historian, DCS and/or SCADA systems for subsequent analysis.

Out of the box VCM-3 detects potential rolling element bearing (REB) machine problems using easy to understand machine fault descriptors. One does not need to find the root cause of the vibration problem to make decisions about asset operation.

This simple approach prevents DCS or SCADA systems from being flooded with information that can mask other issues. The continuous around-the-clock monitoring of the VCM-3 provides the right information, when and where it is needed, without the shortcomings of data gaps or low-quality data of alternate periodic monitoring strategies.

VCM-3 and BKV Go

Some of the basic capabilities of the VCM-3 device are used as the basis for BKV Go.

Up to 12 of the dynamic channels (vibration) are used in the BKV Go Solution and measure ISO 20816 (10 Hz – 1 kHz), Low Frequency (LF), High Frequency (HF) Bandpass vibration and Bearing Condition.

The VCM-3 device ensures that monitoring is working continuously 24/7.

BKV Go provides a Digital Out 1 (DO1) for signaling any present alert condition and a DO2 for any present danger conditions.

Customers can hard-wire from the DO1 and/or DO2 terminal connection to any external alarming device or DCS/PLC as desired.

The upgrade options

If the condition monitoring needs exceed the boundaries of the BKV Go Solution package different upgrade possibilities can be offered based on the VCM-3 device.

The VCM-3 device can potentially offer seamless integration into BKV Beyond which is the cloud solution offering of B&K Vibro. BKV Beyond offers advanced condition monitoring insights for both non-expert and expert users based on AI technology and sophisticated algorithms and comes with a full Remote Monitoring and Diagnostic service as part of the BKV Beyond cloud offering.

The VCM-3 device also has the potential of offering seamless integration into B&K Vibro's SETPOINT® Condition Monitoring System (CMS) powered by AVEVA PI System® to enable vibration analysts to remotely monitor and analyze machine conditions. With all plant data, including waveforms, located in one repository you can unlock the full potential for advanced analytics and automation.

When machine and process conditions dictate a more comprehensive solution and as condition monitoring capabilities grow, we offer services to extend the built-in functionality to optimize a monitoring solution to meet your needs. The VCM-3 device can also be used for monitoring fluid film bearing machines, variable speed machines, and process variables with custom templates offered through our services department. Come talk with us about unlocking the full potential of VCM-3 to optimize your uptime.



EN

Weatherproof Housing

Painted steel housing ¹ (IP66) with a viewing window is delivered with a pre-installed VCM-3 device, 24 V power supply and circuit breaker included.

BKV Go is a Condition Monitoring System consisting of one VCM-3, a 24 VDC power supply and a circuit breaker installed in a painted steel cabinet. The bottom of the cabinet has cable glands preinstalled for input and output cables.

BKV Go is ideal for normal installations as well as installations where increased environmental protection and/or 24 Volts power supply unit is required.

The housing of BKV Go has a hinged lid with a window. The window allows a fast view of the status LEDs on the VCM-3 front plate.

4 M8 x 18 mm threads are provided on the bottom for mounting the cabinet.



NOTE:

- 1. This housing is not rated for hazardous area. Please contact our service department for appropriate housing solutions when deploying in hazardous areas.

Gland layout

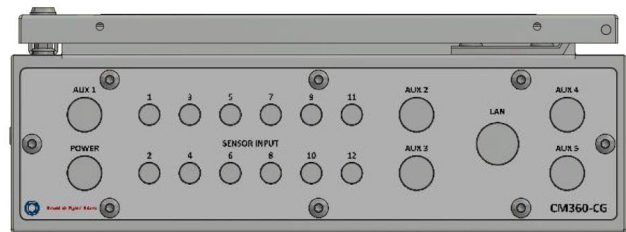

Cable glands

Purpose	Quantity	Size	Cable Diameter
Sensor 1–12	12 pcs	M16	3–6.5 mm (0.118–0.256 in)
External power	1 pcs	M20	6–12 mm (0.236–0.472 in)
Aux	1 pcs	M20	6–12 mm (0.236–0.472 in)
LAN ²	1 pcs	M25	3–6 mm (0.118–0.236 in)

NOTE:

- 2. Allows feed through of RJ-45 LAN connector.

If additional cable glands are required, 4 blind plugs can be exchanged with M20 cable glands. Blinds for cable glands: 8 pcs 5 mm and 1 pcs 8 mm.

Housing dimensions

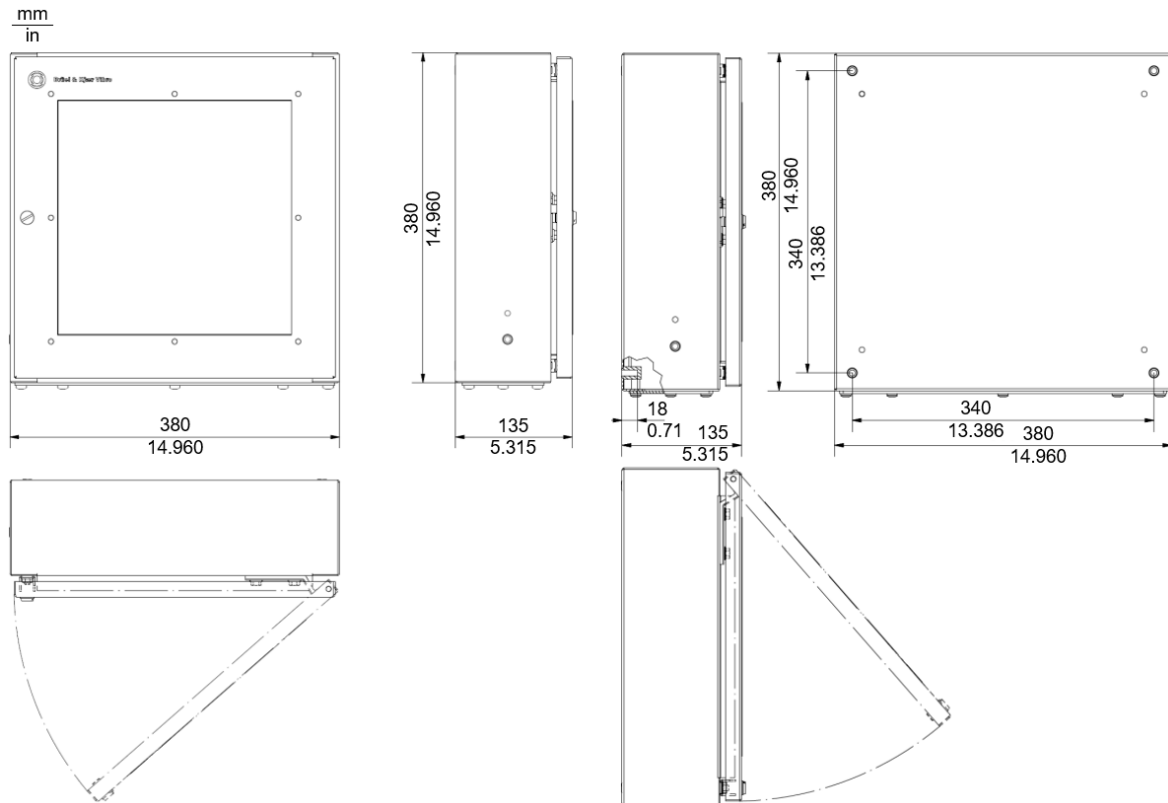

Brüel & Kjær Vibro reserves the right to change specifications without notice

Housing mounting

4 M8 x 18 mm threads are provided at the rear for mounting the cabinet.

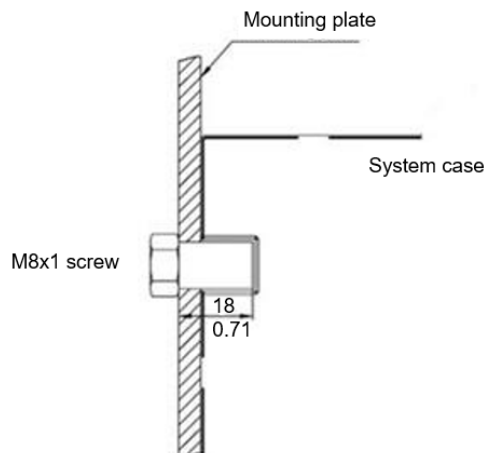



Features and Benefits at a glance

Clear asset status and recommendations for corrective actions

BKV Go offers an easy-to-understand overview of the alarm status for each of the assets covered in the specific monitoring situation. For each asset an alarm will activate when the vibration level exceeds the set alarm limit values. Integrated in the solution is a recommendation matrix which offers guidance for investigation of the error causes.

Automatic alarm settings and continuous monitoring

The solution offers automatic alarm settings without any involvement from the user. During the first hour of operation the alarm limit values are set automatically based on the first 60 measurements made (1 averaged per minute). The solution offers continuous monitoring of the assets ensuring that condition monitoring is a continuous process.

3 different package sizes covering 1–6 assets

BKV Go is offered in 3 different package sizes depending on the amount of assets which need to be monitored utilizing either 4, 8 or 12 channels on the device. Each of the packages can be ordered with or without the optional sensor connection cables.

Easy commissioning via BKV Config website

The commissioning and configuration of the BKV Go Solution is very easy. The configuration is created by following a guided process on the BKV Config website where basic information about the assets can be registered. The configuration should be downloaded to a USB stick (part of delivery), which when inserted into the VCM-3 device, configuration will be automatically uploaded.

OPC UA and Modbus TCP Server embedded in the device

Remove the need for additional software and PC/Server hardware infrastructure for the OPC UA and Modbus TCP Server application as both OPC UA and Modbus TCP are embedded directly into the VCM-3 device.

Ideal stand-alone solution for monitoring motors, pumps and fans

BKV Go is the ideal stand-alone solution for standard applications – it is developed for monitoring constant speed machines with rotational speed above 600 RPM like (electrical) motors, pumps and fans.

Trend data covering the most typical machine faults

BKV Go offers historical trend data and four asset conditions per channel. The visualizations cover the most commonly experienced machine faults in one view.

Collective alarm status Digital Out

BKV Go offers a feature for alert and danger limit value violation supporting hard-wired asset condition indications. By connecting an external alert device (e.g. bell, light, DCS/PLC) the customer will be notified in case of an alert or danger limit value being violated enabling the customer to immediately initiate corrective/investigative actions.

Opportunity for future upgrade to BKV Beyond

The VCM-3 device can potentially offer seamless integration into the BKV Beyond which is the cloud solution offering of BKV.

BKV Beyond offers advanced condition monitoring insights for both non-expert and expert users based on AI technology and sophisticated algorithms. Due to the flexibility of the VCM-3 no hardware replacements are needed for future upgrades.

Opportunity for future upgrade to SETPOINT® CMS and the AVEVA PI System®

Balance of plant condition monitoring has never been easier and more valuable with seamless integration to the AVEVA PI System® and SETPOINT® CMS. The VCM-3 device is prepared for future upgrades if the need for more advanced monitoring solutions develops. No cost-inducing replacements of the hardware are therefore needed for future upgrades.

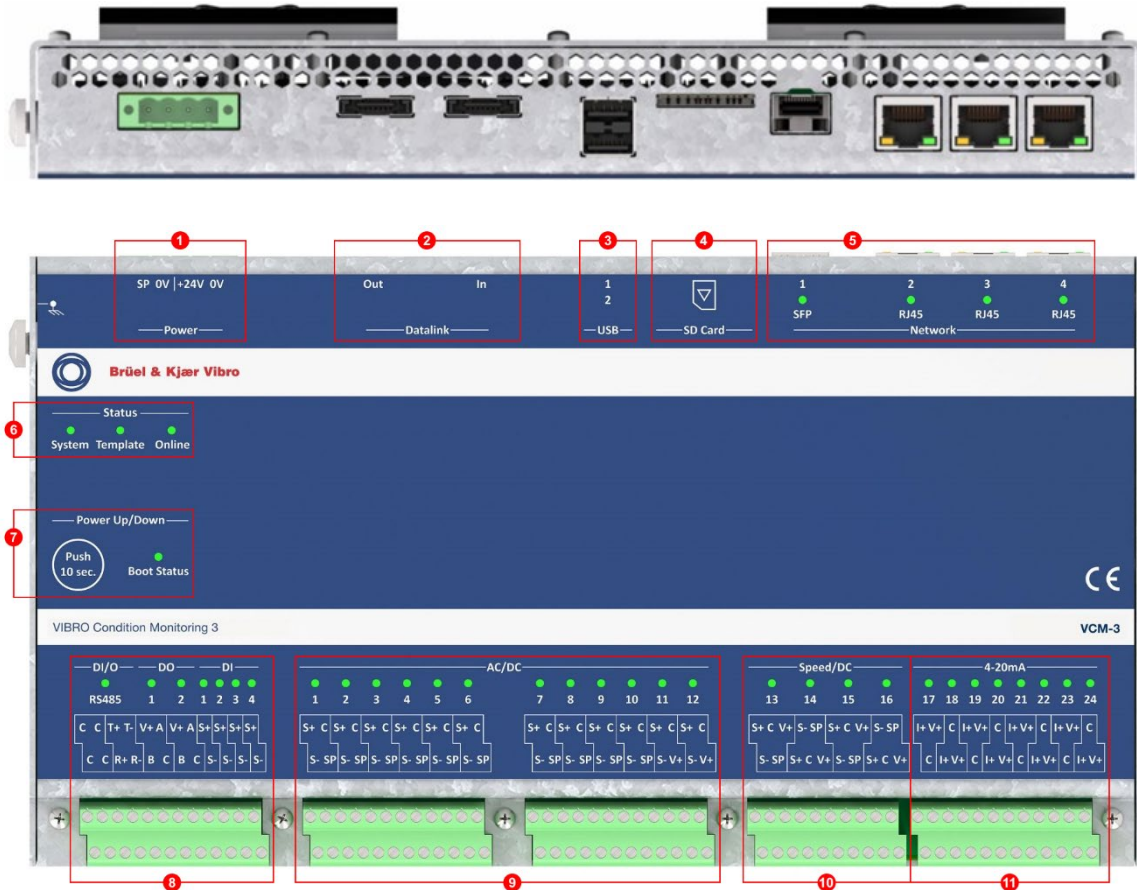

1	Power: 24 V Power Supply separate sensor power	
2	Datalink: Currently not active	
3	USB: 2x USB Type A mass storage	
4	SD Card: SD Card for mass storage	
5	Network: 1x Optical connector, 3x RJ45 connectors (Built-in Ethernet switch)	
6	Status: Watchdog Indicators	
7	Power Up/Down: Power Up/Down and Boot Status	
8	DI/O: RS485 Interface DO: 2x Digital Outputs DI: 4x Digital Inputs	Incl. LED indicators for sensor status and alarm status
9	AC/DC: 12x AC/DC Inputs for CCS accelerometers (ICP), Displacement Probes, Direct Input Voltage	
10	Speed/DC: 4x Speed Inputs	
11	4-20mA: 8x 4–20 mA Input for Process data	



VCM-3 standard monitoring device supports the following connections

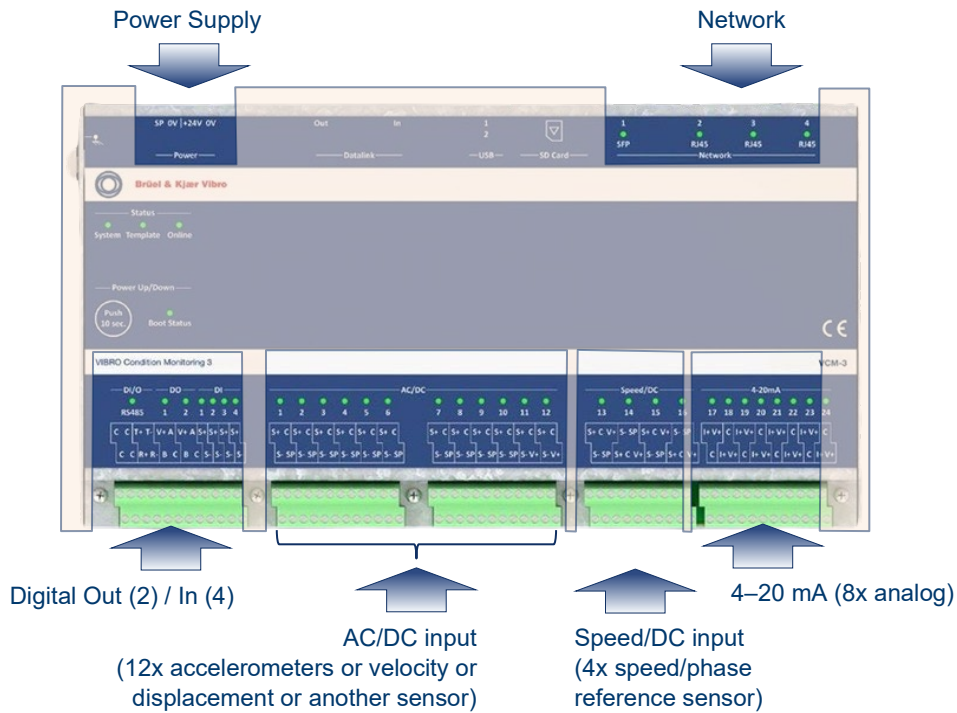

BKV Go standard delivery inputs & outputs

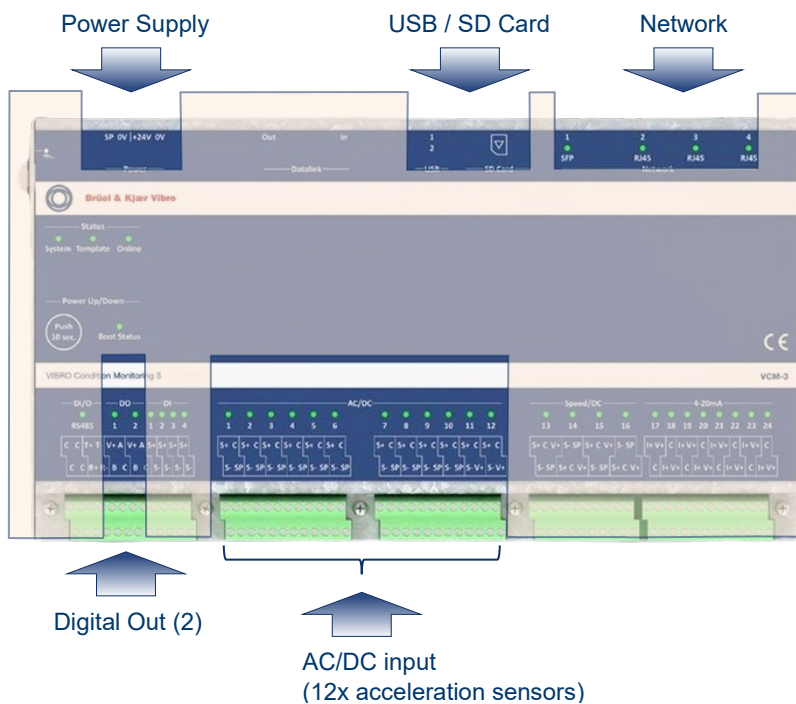

Wiring Diagram

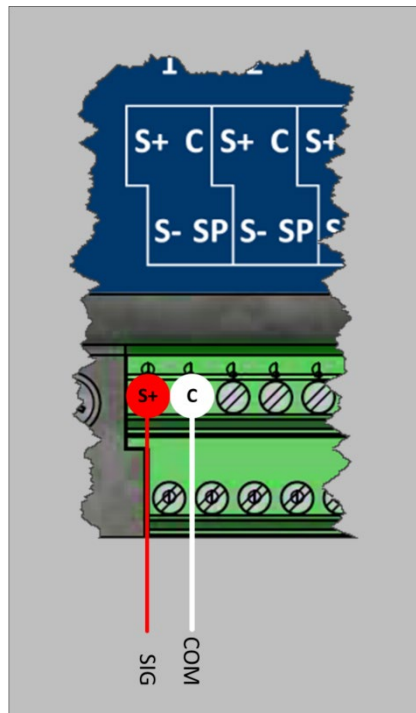

Constant Current Sensors
(e.g. AS-667)

Refer to document *"BKV Go Solution Instructions (C108402)"* for details about sensor installation and wiring.



Technical Specifications

12x AC/DC Analog Input Channels	
A/D converter – one per channel	24 Bit
Sampling Frequency	204.8 kHz synchronous on all channels
Analysis Frequency Range	0.1 Hz – 80 kHz (6–4 800 000 CPM) Lower to upper (filter) corner frequency span minimum 1 : 3 but may not exceed 1 : 5 000
Input Type	Differential, bipolar (-25.5 V to +25.5 V)
Dynamic Range	> 100 dB at 1 kHz, > 94 dB at 0.1 kHz
Channel Interference	> -100 dB
AC Amplitude Accuracy	±0.5 dB
DC Amplitude Accuracy	1 % relative of full scale with ±40 mV Offset.
Total Harmonic Distortion	< 0.01%/250Hz/4Vpp
Input Impedance	> 100 kΩ
Common Mode Rejection	> 50 dB at 50 Hz
Phase Match Between Channels	< 0.3° at 80 kHz

4x Speed/Phase Reference/DC Analog Input Channels	
As Speed/REF Channel (pulse input)	Industrial switches: NPN and, PNP (Namur compatible) Analog: Displacement sensors
Input Range	0–150 000 RPM
Speed Accuracy	500 RPM < 0.04 RPM, 1 500 RPM < 0.1 RPM
Pulse Divider	For use with tachometer signals with multiple pulses per revolution
Sampling Frequency	8 kHz
Accuracy	< ±5 mV Absolute
Dynamic Range	> 100 dB

8x 4–20 mA Analog Input Channels	
Sensor Types	Normal and NAMUR sensor types are accepted
Bandwidth	0–20 Hz
Sampling Frequency	4 kHz
Accuracy	Absolute accuracy < 0.5 %. Non-linearity (typical) < 0.03 %, non-linearity (worst case) < 0.2 %
Offset Current Drift	< 6.5 μV/°C
Current Source	Internal or External

Real Time Descriptor Types (Scalar measurements)	
Time Domain Analysis	Low pass, High pass, Band pass (tracking and fixed), ECU-Envelope Condition Unit (tracking and fixed), BCU-Bearing Condition Unit, DC, Speed, Process Inputs
Frequency Domain Analysis (DFT)	Narrowband – CPB (constant percentage bandwidth) - fixed or tracking Narrowband Envelope Condition Unit – CPB Envelope filter - fixed or tracking
Detectors	RMS, Peak, Peak-Peak, Crest factor, Phase
Physical Parameters	Acceleration, Velocity, Displacement (with proximity probes)
Speed (for tracking analysis)	Either direct from sensor, or derived speed using pulse divider and/or gearbox exchange ratio.
Process	Any 4–20 mA transducer signal. DC via AC/DC or Speed/DC (high accuracy measurements)

Networking	
Network Connections	3x RJ45, 1x optical SFP connector ¹
Low level protocol	Ethernet TCP/IP, IPv4
Switch functionality	4 network ports with built-in switch functionality

System Integration	
OPC UA Server	For data export to controllers, SCADA systems or other system components (internal update rate 5 seconds)
Modbus TCP Server	For data export to SCADA systems or other system components (internal update rate 1 seconds)

Cyber Security	
Secure protocols	Communication takes place through secure and encrypted protocols, such as Web-sockets, HTTPS, SCP.
Port configuration	All services using a TCP/IP port (e.g. https, default port 443) can be configured to use another port
NERC Compliance	The VCM-3 can be part of solutions complying with NERC CIP Standards. (North American Electric Reliability Corporation – Critical Infrastructure Protection).
Strong passwords	The use of strong passwords is enforced. Compliance with NIST SP800-118 – Guide to enterprise Password Management. Can be changed by user.

NOTE:

- The SFP module must support 100BASE-FX over multi-mode fiber (MMF). Cables must be OM3 (50/125 µm) or higher with LC connectors.
 The following modules are verified to work:
 Avago HFBR-57E0ALZ and MicroOptics 100Mb LAN SFP transceivers.

Environmental	
Ambient Temperature	In operation. -30 °C to +60 °C (-22 °F to +140 °F) in accordance to EN/IEC 60068-2-2. Applies to device and to device mounted in cabinet. -40 °C (-40 °F) with reduced accuracy, -70 °C (-94 °F) with de-rated Mean Time Between Failures (MTBF).
Ambient Temperature	Storage. -40 °C to +85 °C (-40 °F to +185 °F) in accordance to EN/IEC 60068-2-2
Temperature Change	Operational during a temperature change rate of 1 °C per minute in accordance to EN/IEC 60068-2-14
Static Damp Heat, Cyclic Damp Heat	In operation. According to EN/IEC 60068-2-78, EN/IEC 60068-2-30 and EN/IEC 60068-2-38.
Random & Sine Vibration	According to EN/IEC 60068-2-6.
Rough Handling	Storage. According to EN/IEC 60068-2-31.
High Altitudes	According to EN/IEC 60068-2-13. Air pressure equivalent to 3500m altitude.
Inclination	According to IEC 60092-504.
IP Rating	The device IP rating is IP20 according to EN/IEC 60529.
HALT Test	Has been subject to HALT test. Excessive vibration and temperatures and combinations hereof
CE-compliant with	EMC acc. 2014/30/EU EN IEC 61326-1 ROHS acc. 2011/65/EU EN IEC 63000:2018 ATEX acc. 2014/34/EU EN IEC 60079-0 EN IEC 60079-7
Hazardous Area Approval (Only available for VCM-3 Ex)	24 V dc / max. 1.6 A / max. 30 W T4 Tamb -30 °C to +60 °C UL Hazardloc Area Approval Class I, Division 2, Groups A–D Class I, Zone 2, Group IIC IECEx Approval IECEx UL 20.0034X Ex ec IIC T4 Gc ATEX Approval UL 20 ATEX 2467 X II 3G Ex ec IIC T4 Gc



Specifications of the housing

Mechanical	
Dimensions	280 x 153.5 x 35 mm (11.02 x 6.02 x 1.38 in)
Weight	1.5 kg (3.31 lbs)
Mounting	DIN Rail Mounting or Wall mount

Power Supply	
Voltage/Power Consumption	18–26 V DC/10 W + power consumption of each sensor.
Fuses	Power supply inputs are fused to protect against over-voltage and fire

Operational	
Fully remote operation	Upload of firmware updates and monitoring templates via network
VCM-3 Homepage	For remote or local service. Commissioning, view of trend and array data, view Log files
Calibration	Factory calibrated. (for re-calibration please contact B&K Vibro)
Service	No specific onsite service required. VCM-3 has no moving parts, or other parts which requires regular service
Design lifetime	20 years

Electrical	
AC Input	100–240 VAC, 1 A 50–60 Hz (fuse at 2–5 A)
DC Input	85–375 VDC

Environmental	
IP rating	IP66
Operating temperature	-10 °C to +55 °C (+14 °F to +131 °F)
CE Marking	In compliance with the EMC, Low Voltage Directive and RoHS 2011/65/EC Directives

Mechanical	
Dimensions	380 x 380 x 135 mm (14.96 x 14.96 x 5.31 in)
Weight	13 kg (28.7 lbs)

Ordering Information

BKV Go – 6 different packages

Use the following order codes when ordering a VCM-3 device or associated accessories. All BKV Go Solutions ship with VCM-3 device, housing, standard template, product documentation, sensors, cables, and sensor monitoring plates.

With cable package

BKV Go 2/1 Combo (with cable package)	
Order Code	Description
BKVG0-2-1/WC	<p>BKV Go 2/1 Combo package with sensor connection cables for 4 channels.</p> <p>Condition Monitoring Solution for balance of plant applications.</p> <p>Package consisting of: -1x VCM-3 monitoring device (preinstalled in a steel housing ¹ with power supply and circuit breaker) -4x AS-667 Acceleration sensor (IEPE) -4x AC-1411/0100 Connection cable, 10 m, with M12 connector -1x AC-274 Sensor Mounting Plate (set of 12 pcs) -Quickstart Guide (C108407, printed)</p>

BKV Go 4/2 Combo (with cable package)	
Order Code	Description
BKVG0-4-2/WC	<p>BKV Go 4/2 Combo package with sensor connection cables for 8 channels.</p> <p>Condition Monitoring Solution for balance of plant applications.</p> <p>Package consisting of: -1x VCM-3 monitoring device (preinstalled in a steel housing ¹ with power supply and circuit breaker) -8x AS-667 Acceleration sensor (IEPE) -4x AC-1411/0100 Connection cable, 10 m, with M12 connector -4x AC-1411/0150 Connection cable, 15 m, with M12 connector -1x AC-274 Sensor Mounting Plate (set of 12 pcs) -Quickstart Guide (C108407, printed)</p>

BKV Go 6/3 Combo (with cable package)	
Order Code	Description
BKVG0-6-3/WC	<p>BKV Go 6/3 Combo package with sensor connection cables for 12 channels.</p> <p>Condition Monitoring Solution for balance of plant applications.</p> <p>Package consisting of: -1x VCM-3 monitoring device (preinstalled in a steel housing ¹ with power supply and circuit breaker) -12x AS-667 Acceleration sensor (IEPE) -4x AC-1411/0100 Connection cable, 10 m, with M12 connector -4x AC-1411/0150 Connection cable, 15 m, with M12 connector -4x AC-1411/0200 Connection cable, 20 m, with M12 connector -1x AC-274 Sensor Mounting Plate (set of 12 pcs) -Quickstart Guide (C108407, printed)</p>

NOTE:

1. This housing is not rated for hazardous area. Please contact our service department for appropriate housing solutions when deploying in hazardous areas.



Without cable package

BKV Go 2/1 Combo (without cable package)	
Order Code	Description
BKVG0-2-1/WOC	<p>BKV Go 2/1 Combo package without sensor connection cables for 4 channels.</p> <p>Condition Monitoring Solution for balance of plant applications.</p> <p>Package consisting of: -1x VCM-3 monitoring device (preinstalled in a steel housing ¹ with power supply and circuit breaker) -4x AS-667 Acceleration sensor (IEPE) -1x AC-274 Sensor Mounting Plate (set of 12 pcs) -Quickstart Guide (C108407, printed)</p>

BKV Go 6/3 Combo (without cable package)	
Order Code	Description
BKVG0-6-3/WOC	<p>BKV Go 6/3 Combo package without sensor connection cables for 12 channels.</p> <p>Condition Monitoring Solution for balance of plant applications.</p> <p>Package consisting of: -1x VCM-3 monitoring device (preinstalled in a steel housing ¹ with power supply and circuit breaker) -12x AS-667 Acceleration sensor (IEPE) -1x AC-274 Sensor Mounting Plate (set of 12 pcs) -Quickstart Guide (C108407, printed)</p>

BKV Go 4/2 Combo (without cable package)	
Order Code	Description
BKVG0-4-2/WOC	<p>BKV Go 4/2 Combo package without sensor connection cables for 8 channels.</p> <p>Condition Monitoring Solution for balance of plant applications.</p> <p>Package consisting of: -1x VCM-3 monitoring device (preinstalled in a steel housing ¹ with power supply and circuit breaker) -8x AS-667 Acceleration sensor (IEPE) -1x AC-274 Sensor Mounting Plate (set of 12 pcs) -Quickstart Guide (C108407, printed)</p>

NOTE:

1. This housing is not rated for hazardous area. Please contact our service department for appropriate housing solutions when deploying in hazardous areas.

Accessories

Accessories – connection cables (straight connector)	
Order Code	Description
AC-1411/0050	AC-1411 M12 Connection Cable, female M12 plug, straight, 5 m
AC-1411/0050/1	AC-1411 M12 Connection Cable, female M12 plug, straight, 5 m, with steel protection conduit
AC-1411/0100	AC-1411 M12 Connection Cable, female M12 plug, straight, 10 m
AC-1411/0100/1	AC-1411 M12 Connection Cable, female M12 plug, straight, 10 m, with steel protection conduit
AC-1411/0150	AC-1411 M12 Connection Cable, female M12 plug, straight, 15 m
AC-1411/0200	AC-1411 M12 Connection Cable, female M12 plug, straight, 20 m
AC-1411/0300	AC-1411 M12 Connection Cable, female M12 plug, straight, 30 m

Accessories – connection cables (angled connector)	
Order Code	Description
AC-1412/0050	AC-1412 M12 Connection Cable, female M12 plug, angled, 5 m
AC-1412/0050/1	AC-1412 M12 Connection Cable, female M12 plug, angled, 5 m, with steel protection conduit
AC-1412/0100	AC-1412 M12 Connection Cable, female M12 plug, angled, 10 m
AC-1412/0100/1	AC-1412 M12 Connection Cable, female M12 plug, angled, 10 m, with steel protection conduit
AC-1412/0150	AC-1412 M12 Connection Cable, female M12 plug, angled, 15 m
AC-1412/0200	AC-1412 M12 Connection Cable, female M12 plug, angled, 20 m

Accessories – mounting	
Order Code	Description
AC-352/025	AC-352/025 Mounting Bolt, M8 x 1.25, length 25 mm, Package contents: 10 pieces
AC-350	AC-350 Mounting Stud, M8 x 1.25, length 14 mm, Minimum order quantity: 10 pieces
AC-351	AC-351 Mounting Stud, M8 x 1.25 to 1/4"-28 UNF, length 11 mm, Minimum order quantity: 10 pieces
AC-277	AC-277 Magnetic Mount Adapter, M8 thread
AC-274	AC-274 Sensor Mounting Plate, for gluing, threaded bold M8, stainless steel (1.4301, V2A), Package contents: 12 pieces



Additional documentation

Document type	Document title	Document no.
Product Specifications and Ordering Information	BKV Go Solution	C108403
	VIBRO Condition Monitoring 3 (VCM-3) – Reliability	C108080
Quickstart Guide	BKV Go Solution	C108407
Instructions	BKV Go Solution	C108402
	VIBRO Condition Monitoring 3 (VCM-3 / VCM-3 Ex) – Safety	C107761
	VIBRO Condition Monitoring 3 (VCM-3 / VCM-3 Ex)	C108418
	CM360-CG/VCM-3	C107899
	AS-667 Acceleration Sensor – Safety	C107912
	AS-667 Acceleration Sensor	C106195
Troubleshooting Guide	VCM-3 Condition Monitoring Unit	C108291
Release Notes	VIBRO Condition Monitoring 3 Firmware	C107825

Documents provided by third parties:

Document type	Document title	Document no.
Data Sheet	Power Supply	
	Circuit Breaker	

Contact Us

Brüel & Kjær Vibro GmbH

Wittichstrasse 6
64295 Darmstadt
Germany

Phone: +49 6151 428 0
Fax: +49 6151 428 1000

General e-mail

info@bkvibro.com

Brüel & Kjær Vibro A/S

Lyngby Hovedgade 94, 5 sal
2800 Lyngby
Denmark

Phone: +45 69 89 03 00
Fax: +45 69 89 03 01

Homepage

www.bkvibro.com

BK Vibro America Inc.

1100 Mark Circle
Gardnerville NV 89410
USA

Phone: +1-775-552-3110